

Harman Patents

Inventors: David E. Seitz, Conroe; David Paul Sharp; Thomas Lamson Harman, both of Houston; Louis J. Everett, College Station; Rodney H. Neumann, The Woodlands, all of TX (US)

**United States Patent 6,246,831 4 Chamber
Seitz, et al.: June 12, 2001
Fluid heating control system**

Abstract

An improved system, method and apparatus for control of an instantaneous flow-through fluid heater system is disclosed. The control incorporates a logic control method providing modulation of power in small steps to a plurality of heating elements retaining responsiveness to closed-loop control needs without inducing light flicker. Further, the life of the coils of heating circuit electromechanical relays are extended by energizing the coils with a pulse-width-modulated drive decreasing in duty cycle and thus the latent coil heat when an increase in mains voltage is sensed. The life of the contacts of same relays are extended by inhibiting heating element triac drive immediately upon sensing loss of relay coil power, such as by an over temperature limit switch opening, thus ensuring that relay contacts open with zero heating element current. In addition to the software "watchdog timer" internal to the microcontroller, a redundant fail-safe circuit external to the microcontroller prevents a program lockup condition from leaving any heating element triac or relay drive in an energized state. A combination of control hardware and program provide self-diagnostic detection of an inoperative thermistor, stuck relay, or a failed triac or heating element. An improved means of sensing water level is disclosed incorporating a low-level, high frequency signal, allowing detection of non-conducting distilled water and the reliable detection of water in the presence of main-frequency currents as would exist in ungrounded sheathed heating elements with electrical leakage or as would exist with bare-elements.

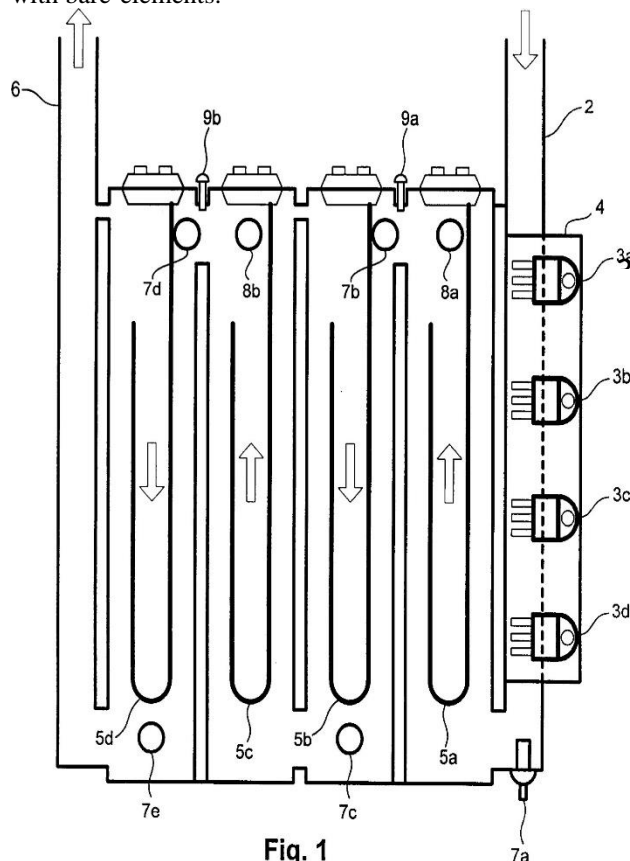

Fig. 1

1 Chamber

0) **Patent No.:** US 10,024,571 B2

5) **Date of Patent:** Jul. 17, 2018

(54) **TANKLESS WATER HEATER**

(71) Applicant: **David E. Seitz**, San Antonio, TX (US)

(72) Inventors: **David E. Seitz**, San Antonio, TX (US);
James Dabney, Houston, TX (US);
Louis Everett, El Paso, TX (US);
Thomas L. Harman, Houston, TX (US)

U.S. Patent

Jul. 17, 2018

Sheet 1 of 9

US 10,024,571 B2

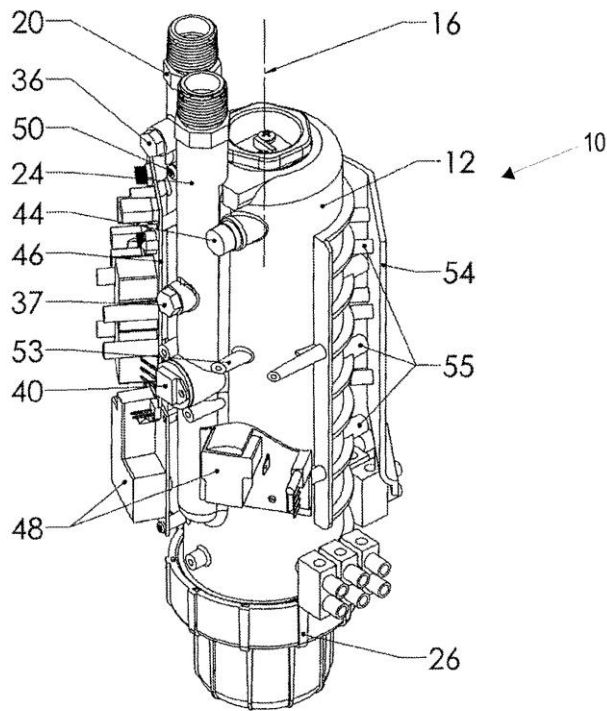

FIGURE 1

(10) **Patent No.:** US 9,664,413 B2
(45) **Date of Patent:** May 30, 2017

(54) **TANKLESS WATER HEATER**

(71) Applicant: **David E. Seitz**, San Antonio, TX (US)

(72) Inventors: **David E. Seitz**, San Antonio, TX (US);
James Dabney, Houston, TX (US);
Louis Everett, El Paso, TX (US);
Thomas L. Harman, Houston, TX (US)

(73) Assignee: **David E. Seitz**, San Antonio, TX (US)

