

SENSORS 4 MOBILE ROBOTICS

CENG 5437, CENG 4391 SPRING 2023



TOPICS

Types of Sensors

Sensor Characteristics

Angular Position: Rotary Encoder

Gyroscopes

Compass Sensors

TI Summary Chart

Cameras and Depth

IR and Sonar

Lidar and Radar

GPS

Kaarta Engine

Types of sensors

Specific examples

- tactile
- close-range proximity
- angular position
- infrared
- Sonar
- laser (various types)
- radar
- compasses, gyroscopes
- Force
- GPS
- vision

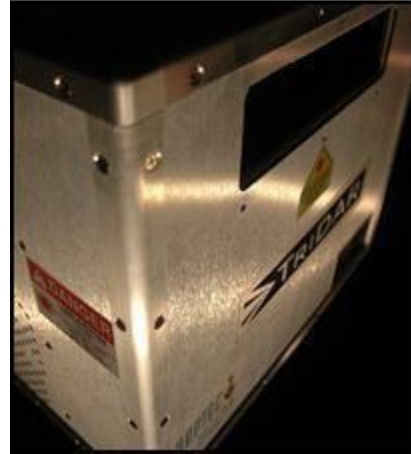

Ioannis Rekleitis

Sensors

- **Proprioceptive Sensors**

(monitor state of robot)

- IMU (accels & gyros)
- Wheel encoders
- Doppler radar ...

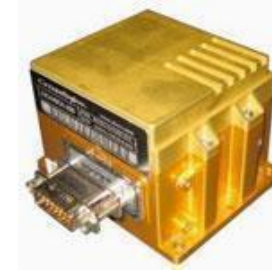

- **Exteroceptive Sensors**

(monitor environment)

- Cameras (single, stereo, omni, FLI)
- Laser scanner
- MW radar
- Sonar
- Tactile...





Sensor Characteristics

- **Response Time:** time required for a change in input to cause a change in the output
- **Accuracy:** difference between measured & actual
- **Repeatability:** difference between repeated measures
- **Resolution:** smallest observable increment
- **Bandwidth:** result of high resolution or cycle time

Accuracy and errors

. Systematic errors

- . Result from a variety of factors
 - . Interfering or modifying variables (i.e., temperature)
 - . Drift (i.e., changes in chemical structure or mechanical stresses)
 - . The measurement process changes the measurand (i.e., loading errors)
 - . The transmission process changes the signal (i.e., attenuation)
 - . Human observers (i.e., parallax errors)
- . **Systematic errors can be corrected with COMPENSATION methods (i.e., feedback, filtering)**

. Random errors

- . Also called NOISE: a signal that carries no information
- . True random errors (white noise) follow a Gaussian distribution
- . Sources of randomness:
 - . Repeatability of the measurand itself (i.e., height of a rough surface)
 - . Environmental noise (i.e., background noise picked by a microphone)
 - . Transmission noise (i.e., 60Hz hum)
- . Signal to noise ratio (SNR) should be $\gg 1$
 - . With knowledge of the signal characteristics it may be possible to interpret a signal with a low SNR (i.e., understanding speech in a loud environment)



Example: systematic and random errors

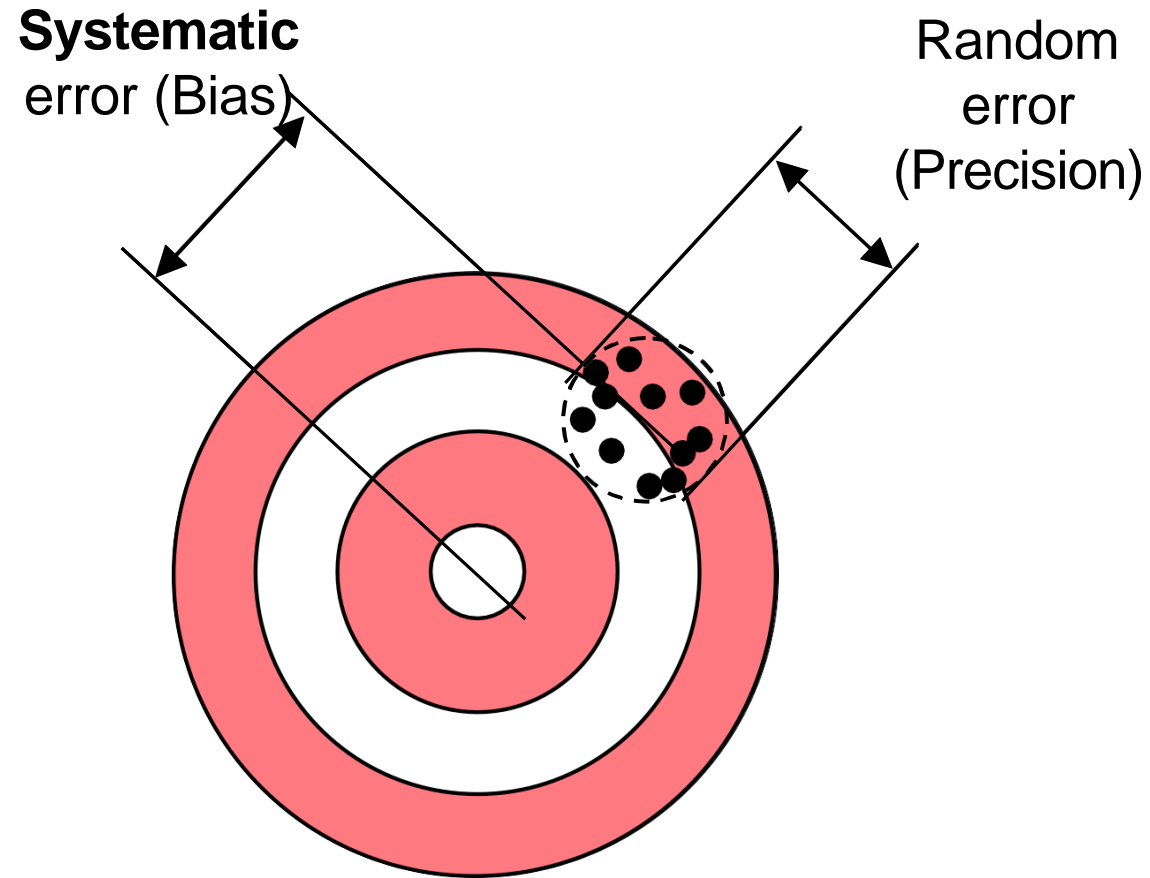

Angular Position: Rotary Encoder

- Potentiometer
 - Used in the Servo on the boebots
- Optical Disks (Relative)
 - Counting the slots
 - Direction by having pairs of emitters/receivers out of phase: Quadrature decoding
 - Can spin very fast: 500 kHz

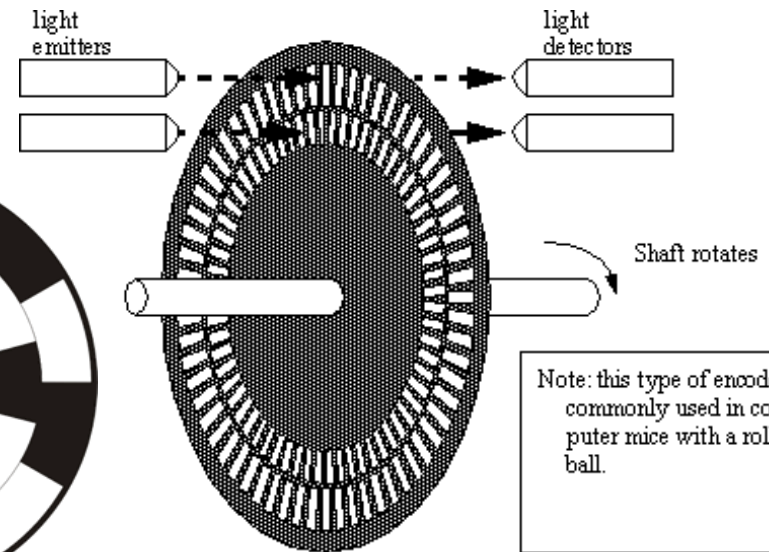
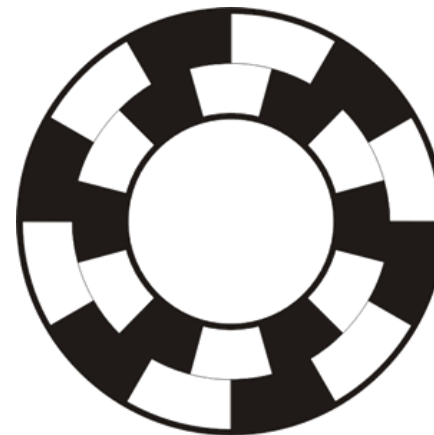
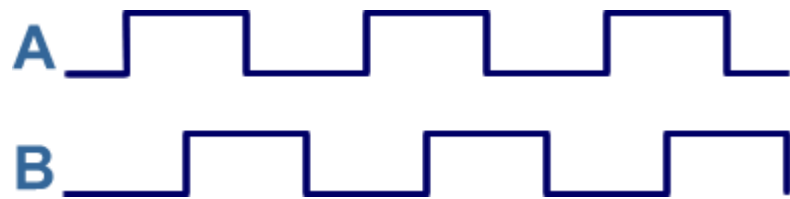
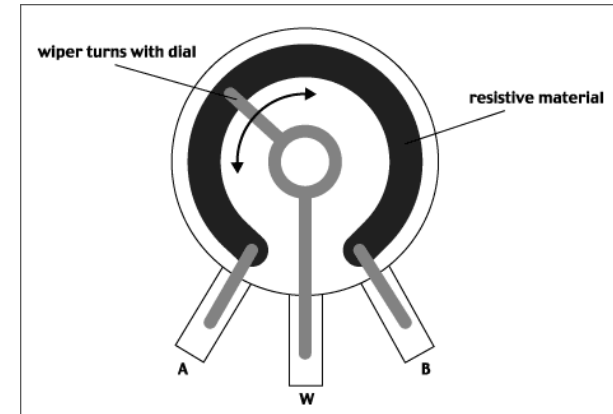

Note: this type of encoder is commonly used in computer mice with a roller ball.

Gyroscopes

- A gyroscope is a spinning wheel with most of its mass concentrated in the outer periphery
 - e.g. a bicycle wheel
- Due to the law of *conservation of momentum*
 - the spinning wheel will stay in its original orientation
 - a force is required to rotate the gyroscope
- A gyro. can thus be used to maintain orientation or to measure the rate and direction of rotation
- In fact there are different types of mechanical gyro.
 - and even optical gyro's with no moving parts!
 - these can be used in e.g. space probes to maintain orientation

Ring gyro's

- Use standing waves set up
 - between mirrors (laser ring gyro)
 - within a fiber optic cable (fibre optic ring gyro)
- Measure rotation by observing beats in standing wave as the mirrors "rotate through it".

IMU's

- Gyro, accelerometer combination.
- Typical designs (e.g. 3DM-GX1™) use tri-axial gyros to track dynamic orientation and tri-axial DC accelerometers along with the tri-axial magnetometers to track static orientation.
- The embedded microprocessors contains programmable filter algorithms, which blend these static and dynamic responses in real-time.

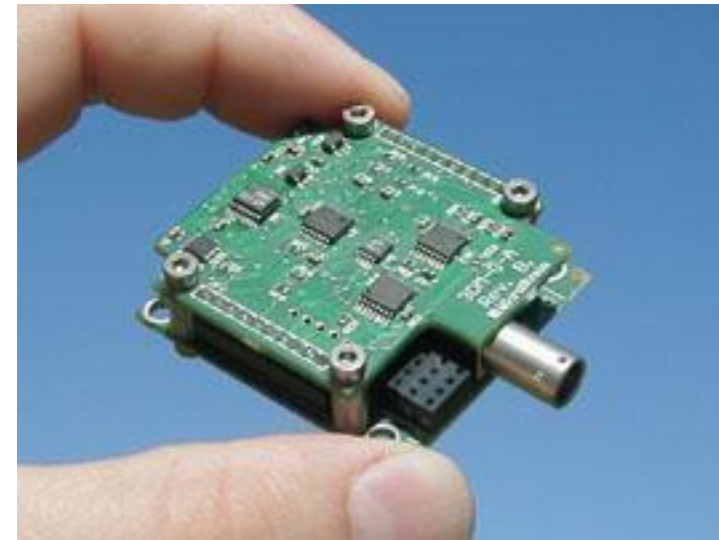

Vibrating Structure Gyroscopes

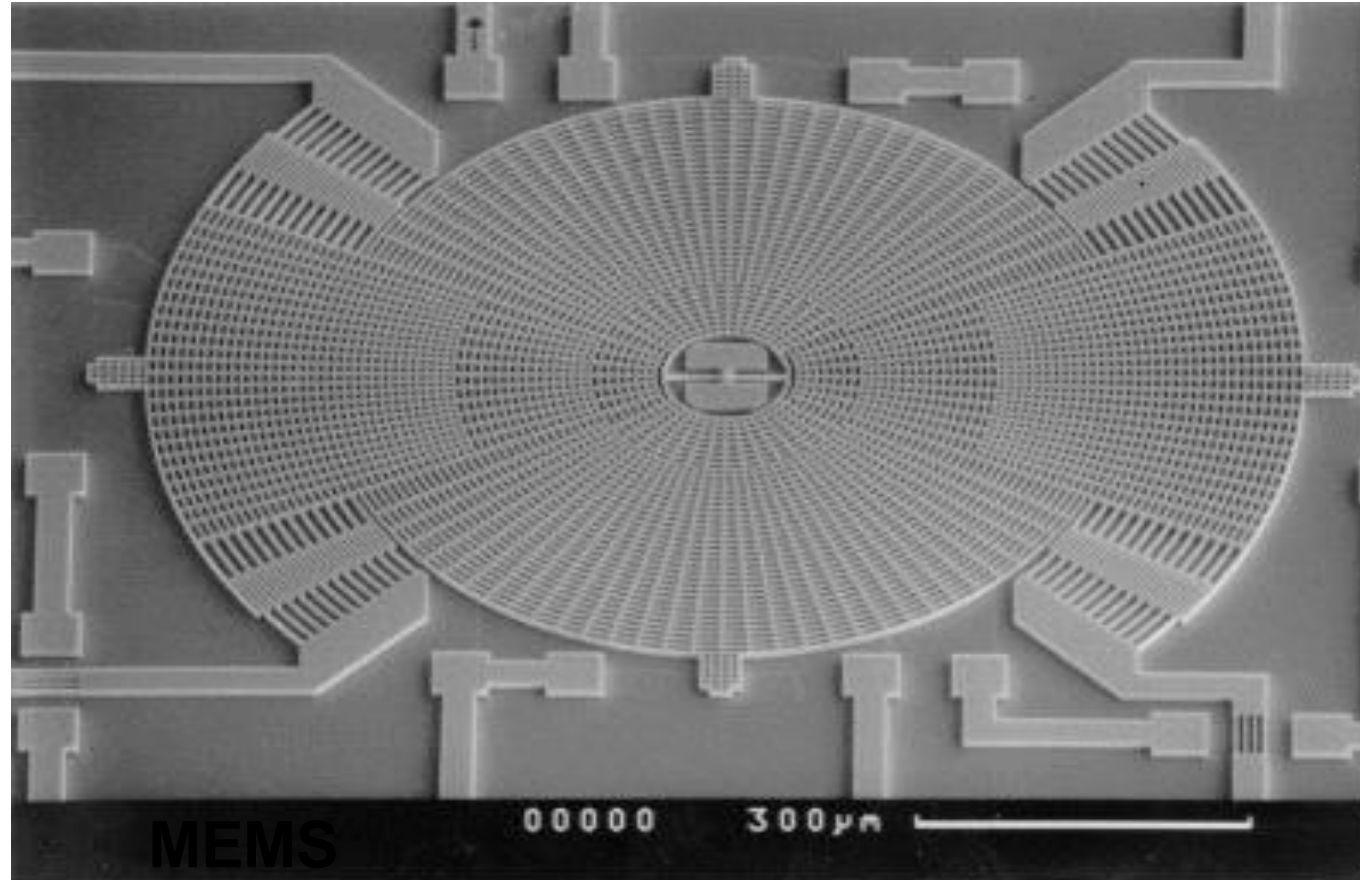

Compass Sensors

- Compass sensors measure the horizontal component of the earth's magnetic field
 - some birds use the vertical component too
- The earth's magnetic field is very **weak** and **non-uniform**, and **changes over time**
 - indoors there are likely to be many other field sources
 - steel girders, reinforced concrete, power lines, motors, etc.
 - an accurate absolute reference is unlikely, but the field is approx. constant, so can be used for local reference

TI Summary Chart

Rectangular Snip

CLOS

Texas Instruments Sensor Summary Chart

Robotics

Sensors	Detection range	Detection angle	Range resolution	Detectable information	Bad weather	Night operation	Detection performance
mmWave 	Long	Narrow and wide	Good	Velocity, range, angle	Good	Yes	Robust and stable
Camera 	Medium	Medium	Medium	Target classification	Poor	No	Complexity to calculate object coordinates
LIDAR 	Long	Narrow and wide	Good	Velocity, range, angle	Poor	No	Poor in bad weather
Ultrasonic 	Short	Wide	Good	Range	Poor	No	Short-range applications
CapTIvate 	Short	Narrow	Good	Proximity, pressure	Good	Yes	Very short-range applications

Camera and Depth Sensor



Kinect for Xbox 360



Kinect for Xbox One



Kinect for Windows v2

Microsoft Kinect versions

Baxter In Color



An image view of an rgb image

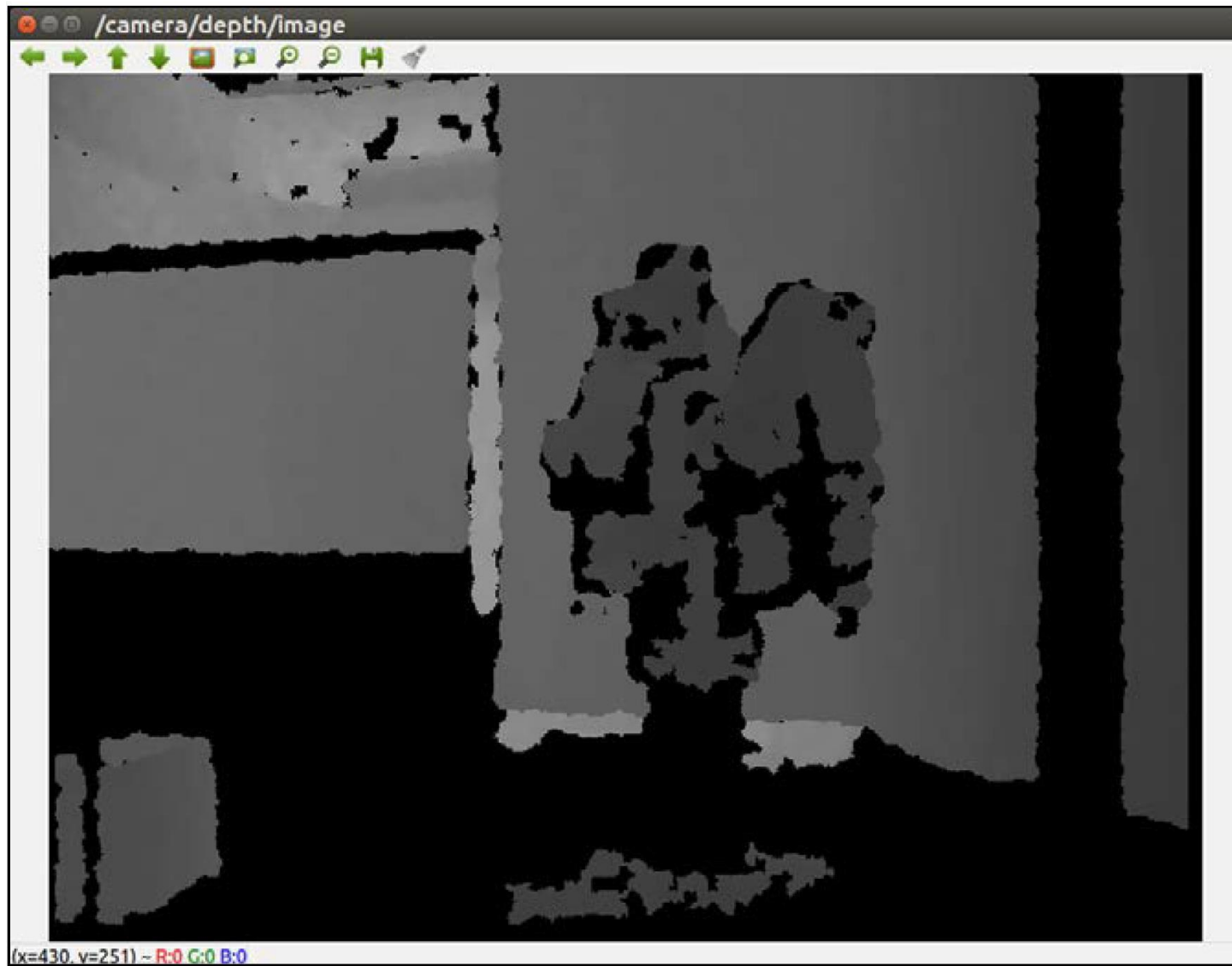

An image view of a depth image

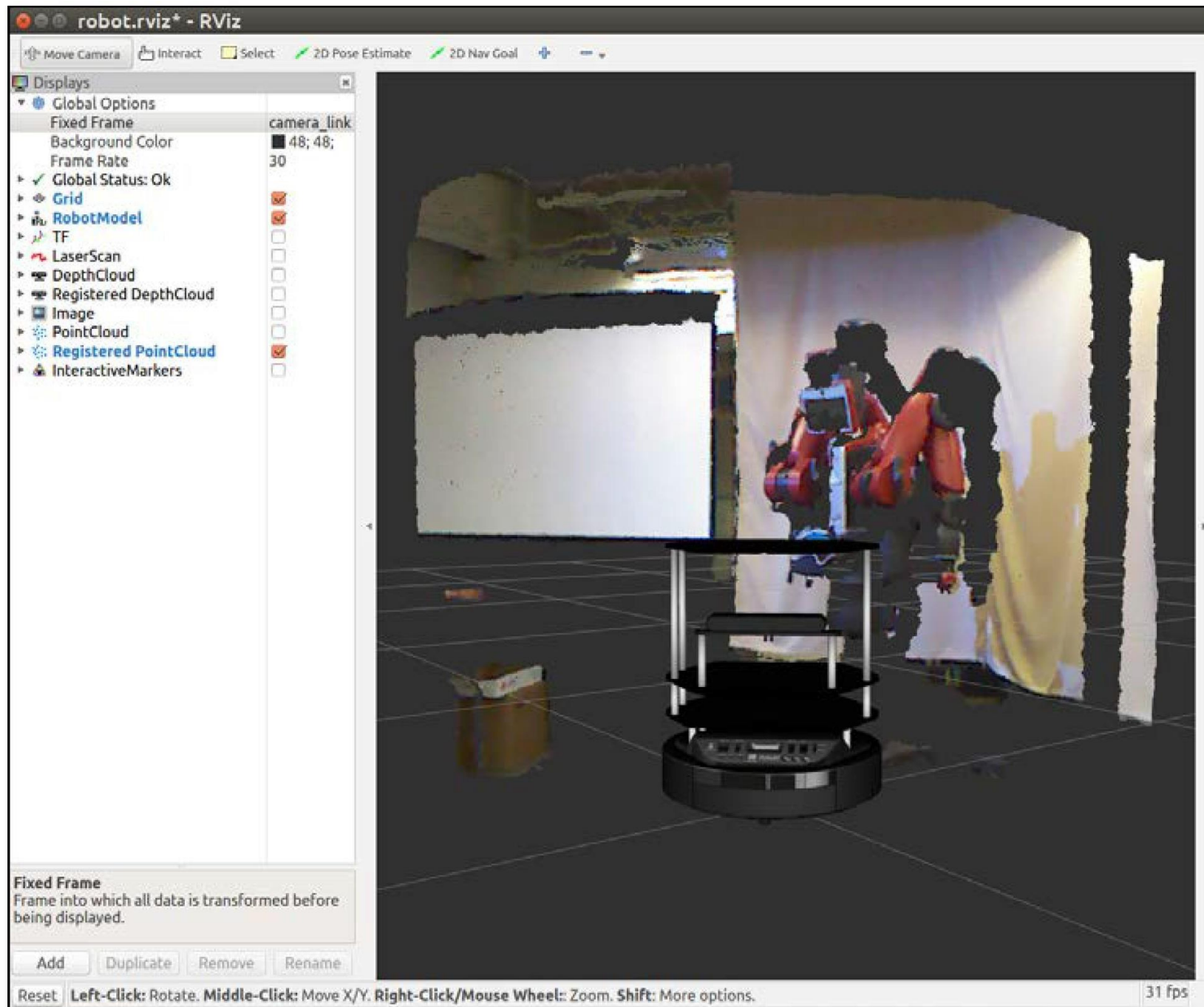

A Registered PointCloud image

Microsoft kinect

Microsoft Kinect version specifications:

Spec	Kinect 360	Kinect One	Kinect for Windows v2
Release date	November 2010	November 2013	July 2014
Horizontal field of view (degrees)	57	57	70
Vertical field of view (degrees)	43	43	60
Color camera data	640 x 480 32-bit @ 30 fps	640 x 480 @ 30 fps	1920 x 1080 @ 30 fps
Depth camera data	320 x 240 16-bit @ 30 fps	320 x 240 @ 30 fps	512 x 424 @ 30 fps
Depth range (meters)	1.2–3.5	0.5–4.5	0.5–4.5
Audio	16-bit @ 16 kHz	4 microphones	
Dimensions	28 x 6.5 x 6.5 cm	25 x 6.5 x 6.5 cm	25 x 6.5 x 7.5 cm
Additional information	Motorized tilt base range \pm 27 degrees; USB 2.0	Manual tilt base; USB 2.0	No tilt base; USB 3.0 only
	Requires external power		

Table 2 - Comparison Matrix of Current Sensor Technologies

	Ultrasonic	LIDAR	RADAR	Bi-Static Radar	Vision	AIR Active	PIR Passive
Cost	Low	High	High	Medium	Medium	Low	Low
Computation Overhead	Low	High	Medium	Medium	High	Low	Low
Range	3m	5m to 150m	1m to 150m	5m	Line of sight	2m	20m
Operating Conditions	Clear visibility	Clear visibility to 150m	Normal to heavy rain or snow	Normal to heavy rain or snow	Clear visibility	Normal to slight haze	Clear visibility
Commercially Available	Yes	Yes	Yes	No	Yes	Yes	Yes
Industry Acceptance	High	None	Some	None	None	None	None
Accuracy	$\pm 0.05m$	$\pm 0.3m$	$\pm 1.0m$	$\pm 0.1m$	NA	NA	NA
Update Frequency	40Hz	400Hz	10Hz	5kHz	<30Hz	NA	NA
Potential for Object Discrimination	Low	Some	Low	Low	High	None	Low
Detection Capabilities	Distance	Distance, speed, geometry	Distance, speed, cross section	Distance and radar cross section	Distance, speed, geometry, object class data	Presence	Presence
Minimum Target Size	Basketball	1" square or larger	Motorcycles and larger	Motorcycles, Pedestrians, and larger	Varies with distance	Pedestrians	Small animals

Infrared Problems

- If the IR signal is detected, it is safe to assume that an object is present
- However, the absence of reflected IR does not mean that no object is present!
 - “Absence of evidence is not evidence of absence.”
C. Sagan
 - **certain dark colours (black) are almost invisible to IR**
 - IR sensors are not absolutely safe for object detection
- In realistic situations (different colours & types of objects) there is no accurate distance information
 - it is best to avoid objects as soon as possible
- **IR are short range**
 - typical maximum range is 50 to 100 cm

Sonar Problems

- There are a number of problems and uncertainties associated with readings from sonar sensors
 - **it is difficult to be sure in which direction an object is because the 3D sonar beam spreads out as it travels**
 - *specular reflections* give rise to erroneous readings
 - the sonar beam hits a smooth surface at a shallow angle and so reflects away from the sensor
 - only when an object further away reflects the beam back does the sensor obtain a reading - *but distance is incorrect*
 - arrays of sonar sensors can experience *crosstalk*
 - one sensor detects the reflected beam of another sensor
 - **the speed of sound varies with air temp. and pressure**
 - a 16° C temp. change can cause a 30cm error at 10m!

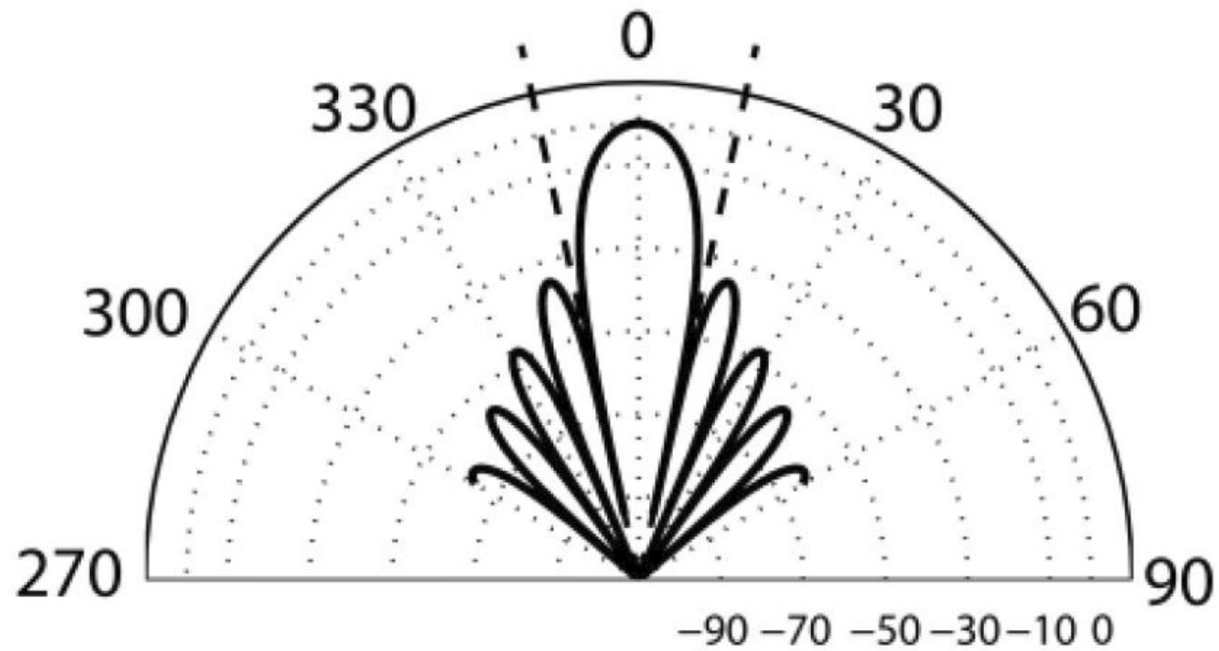

Sonar Sensor Models and Their Application to Mobile Robot Localization

[Antoni Burguera](#), *Yolanda González, and Gabriel Oliver

Ultrasonic sensor control using ROS and Arduino

As an example of interfacing a sensor with the Arduino board, we will add an HC-SR04 ultrasonic range sensor. The following screenshot shows the face of the sensor:



HC-SR04 ultrasonic sensor

Working Voltage	DC 5 V
Working Current	15mA
Working Frequency	40Hz
Max Range	4m
Min Range	2cm
MeasuringAngle	15 degree
Trigger Input Signal	10uS TTL pulse
Echo Output Signal	Input TTL lever signal and the range in proportion
Dimension	45*20*15mm

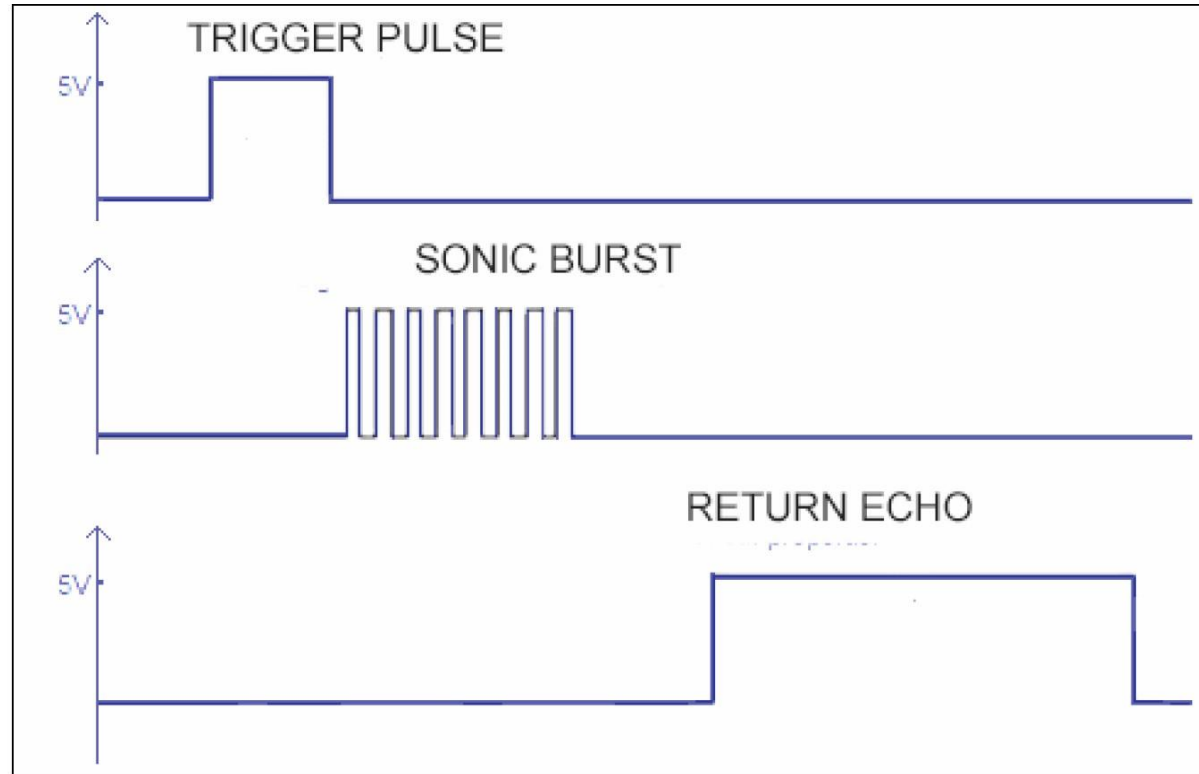

HC-SR04 sensor signals

According to the specifications of the HC-SR04 sensor, the trigger pulse created by the software must be at least 10 microseconds long. The repetition time to measure the distance to an obstacle must be greater than 25 milliseconds to ensure that the trigger pulses do not overlap in time with the return echo pulse. This is a repetition rate of 40 hertz. In the code to follow, the repetition time for the published range is set at 50 milliseconds.

Lidar and Radar

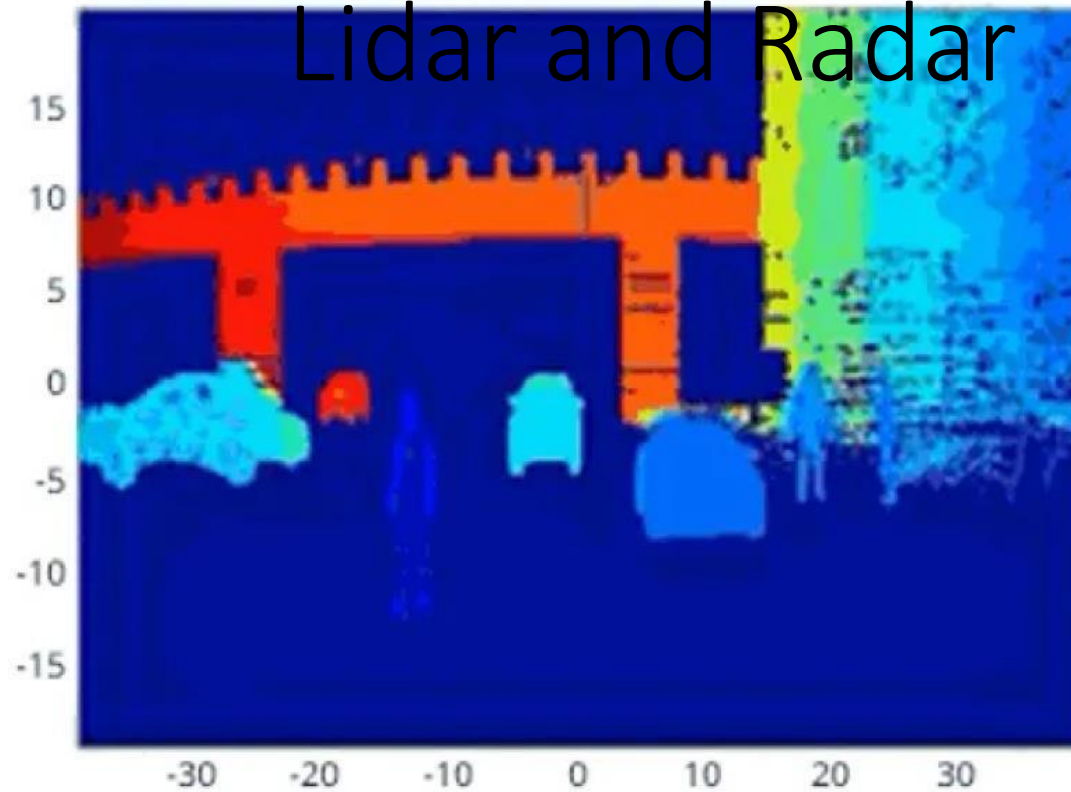

Lidar

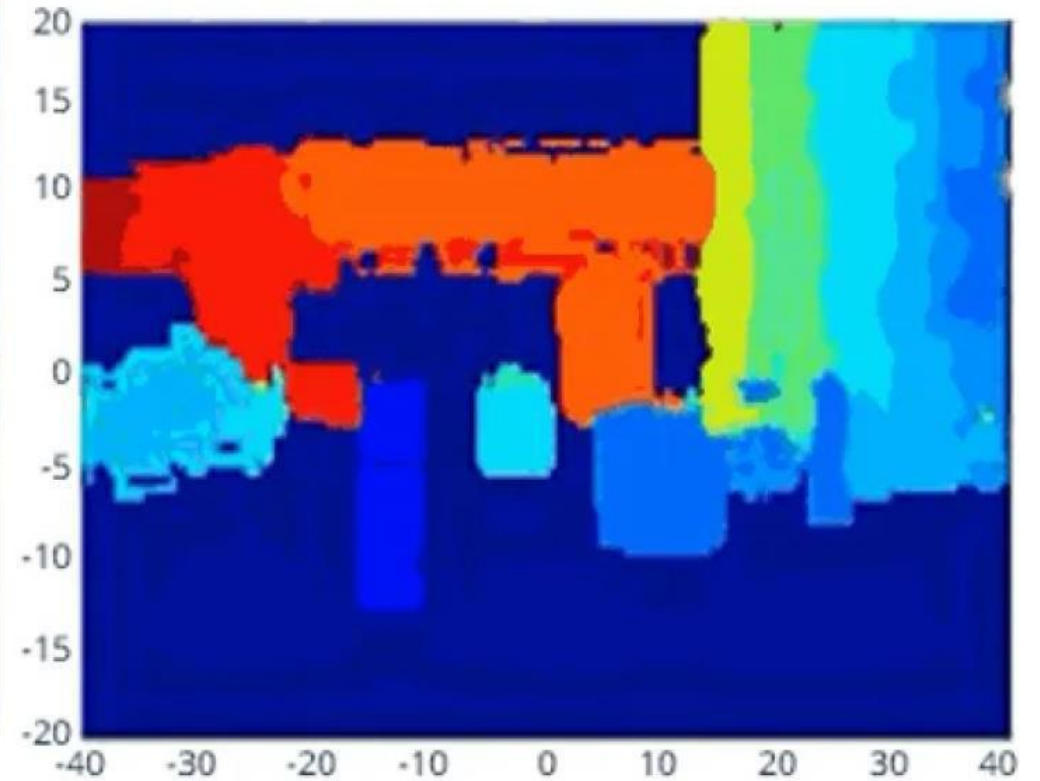

High Resolution Radar

A comparison of LiDAR's and RADAR's accuracy

<https://www.wevolver.com/article/lidar-vs-radar-detection-tracking-and-imaging#:~:text=Thanks%20to%20this%2C%20LiDAR%20has,with%20a%20lower%20starting%20price>

Laser Range Finders

- Laser range finders commonly used to measure the *distance, velocity* and *acceleration* of objects
 - also known as *laser radar* or *lidar*
- The operating principle is the same as sonar
 - a short pulse of (laser) light is emitted
 - the time elapsed between emission and detection is used to determine distance (using the speed of light)
- Due to the shorter wavelengths of lasers, the chance of specular reflections is much less
 - **accuracies of millimetres** (16 - 50mm) over 100m
 - 1D beam is usually swept to give a 2D planar beam
- **May not detect transparent surfaces (e.g. glass!) or dark objects**

THE ELECTROMAGNETIC SPECTRUM

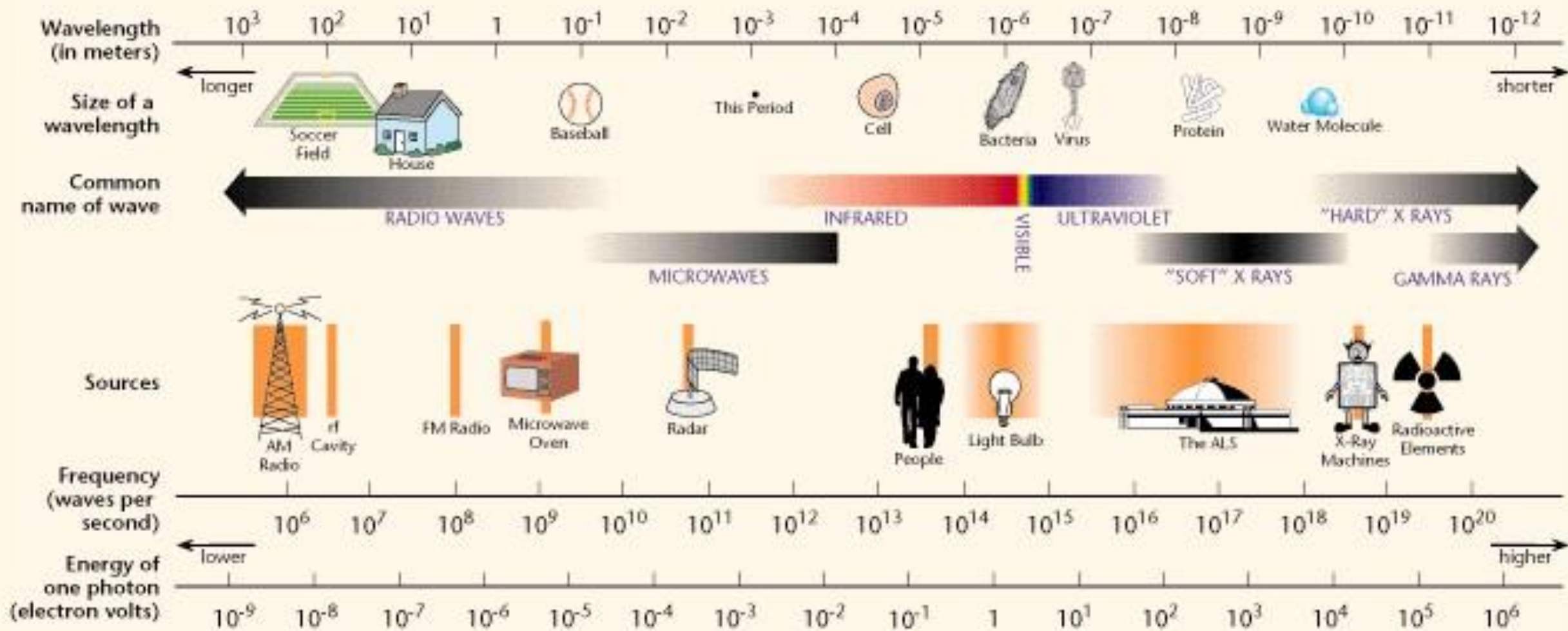

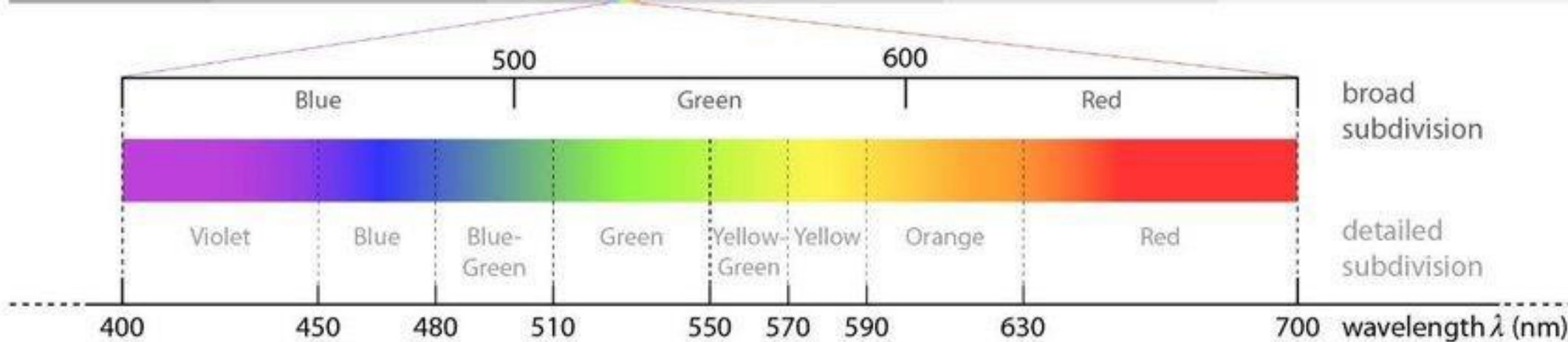
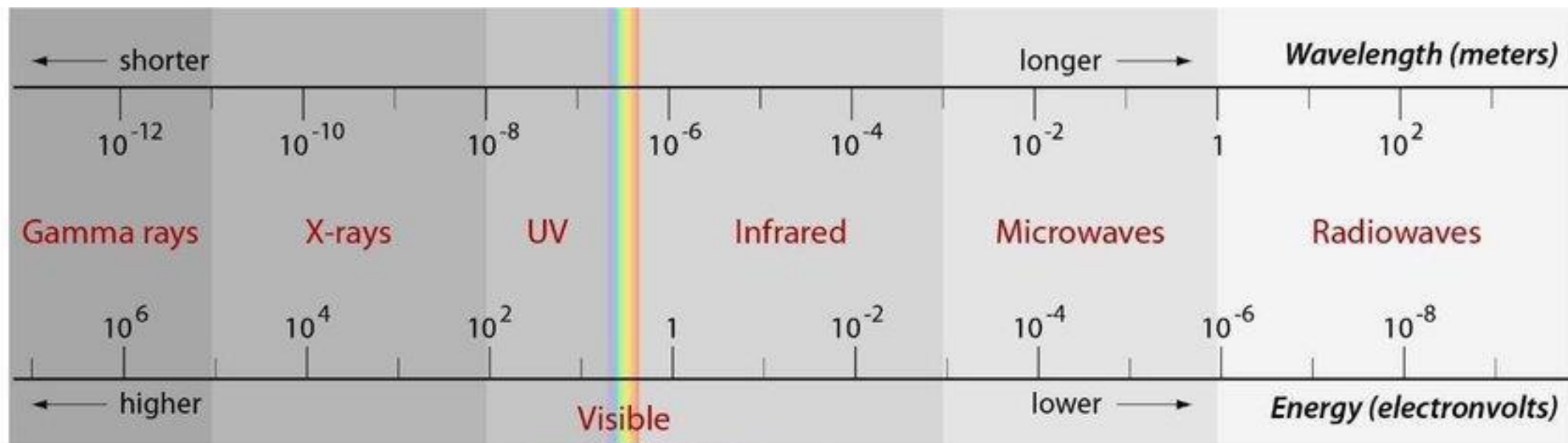

10 Meter Amateur Band

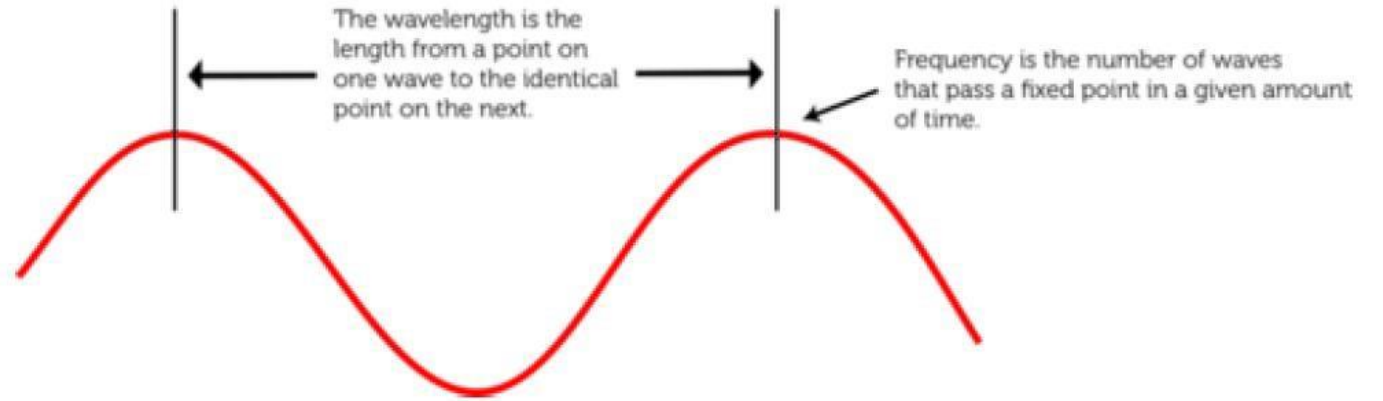

Enter the Wavelength to Calculate the Frequency

Wavelength

m

Calculate

Reset

Result

Frequency

29.9792458

MHz

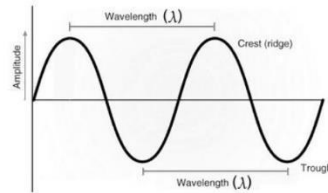

[Click here to view image](#)

$$f = C/\lambda \text{ Hertz}$$

ABOUT 30 METER WAVELENGTH

RADAR

- Radar usually uses electromagnetic energy in the 1 - 12.5 GHz frequency range
 - this corresponds to wavelengths of 30 cm - 2 cm
 - microwave energy
 - unaffected by fog, rain, dust, haze and smoke
- It may use a pulsed time-of-flight methodology of sonar and lidar; but may also use other methods
 - continuous-wave phase detection
 - continuous-wave frequency modulation
- Continuous-wave systems make use of Doppler effect to measure relative velocity of the target

TI Radar Applications

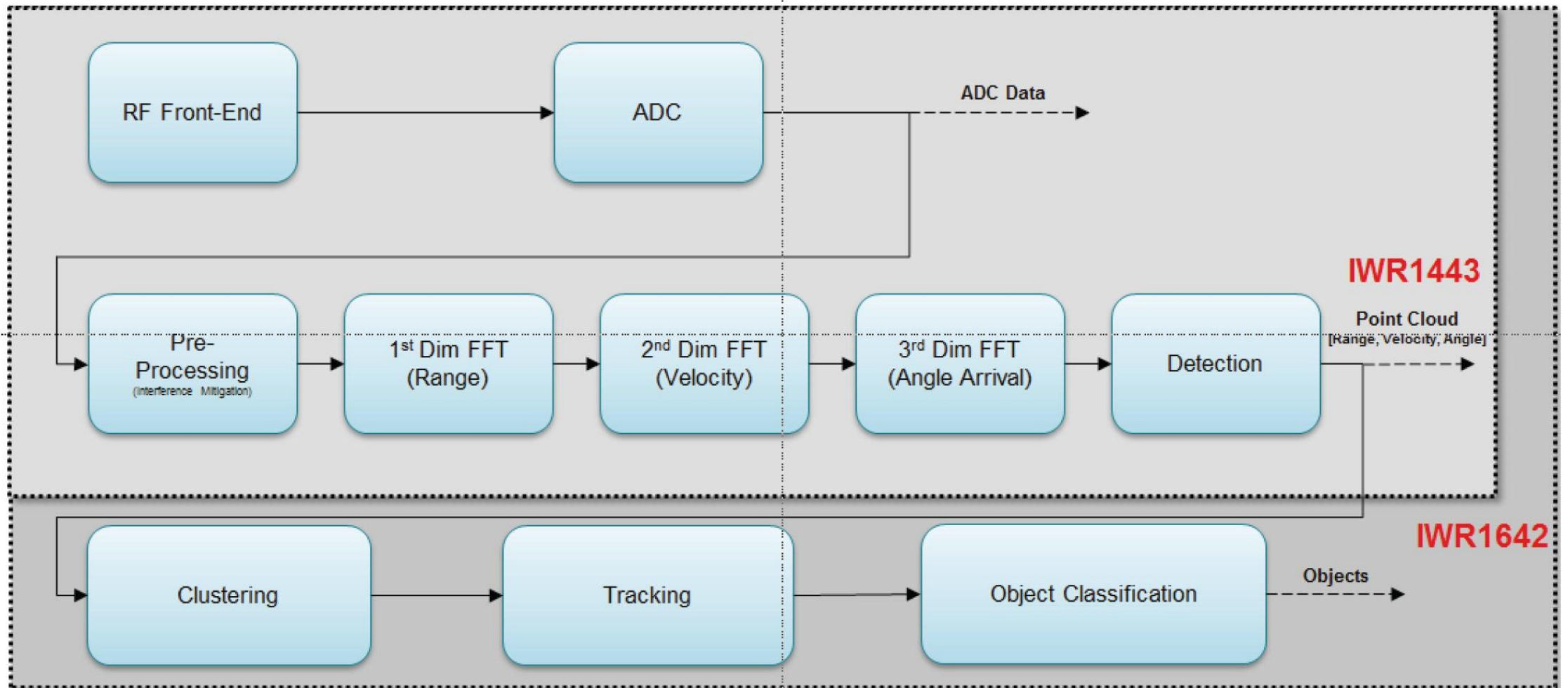

Figure 7. TI IWR mmWave sensors processing chain.

Doppler Effect

The Doppler effect is the change in the observed frequency of an (electromagnetic) wave due to relative motion of the source and observer.

From: [Microclimate for Cultural Heritage \(Second Edition\), 2014](#)

Related terms:

[Acoustic Doppler Current Profiler](#), [Spacecraft](#), [Wavelength](#), [Transmitter](#), [Radial Velocity](#), [Frequency Shift](#), [Resonance](#), [Reactivity](#), [Photon](#)

WATCH YOUR SPEED

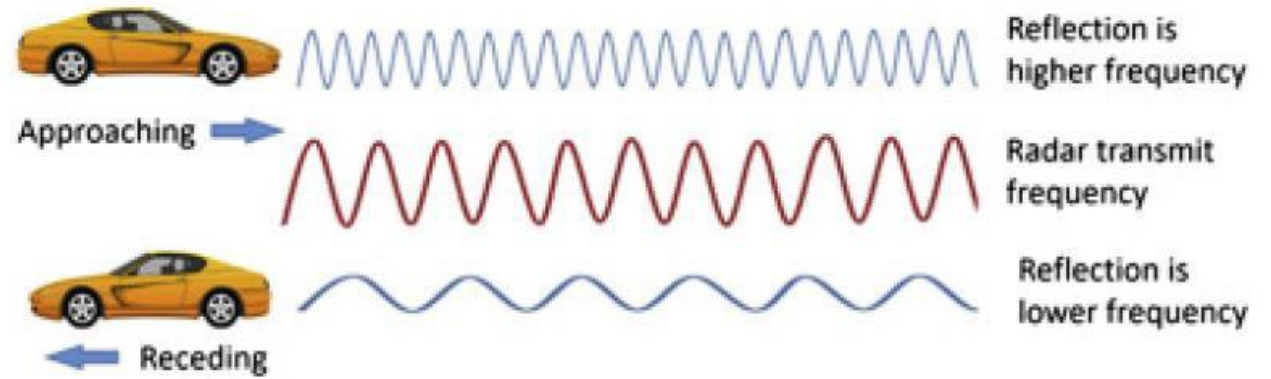

Figure 4.7. Doppler effect.

In Doppler effect, the relationship between the received frequency f and the transmitted frequency f_0 is given by

$$f = \left(\frac{c+v_T}{c+v_s} \right) f_0 = \left(1 + \frac{v_T - v_s}{c+v_s} \right) f_0 \quad (4.3)$$

where c is the velocity of radio waves in the medium, v_T is the velocity of the receiver with respect to the medium and v_s is the velocity of the source with respect to the medium. If the speeds, v_T and v_s , are small compared to the speed of the wave c , the relationship between f and f_0 can be approximated by

$$\Delta f = f - f_0 \approx \left(\frac{\Delta v}{c} \right) f_0 \quad (4.4)$$

where $\Delta v = v_T - v_s$. Thus we can acquire the relative speed Δv by the detection of the frequency shift Δf .

What Neil & Buzz Left on the Moon

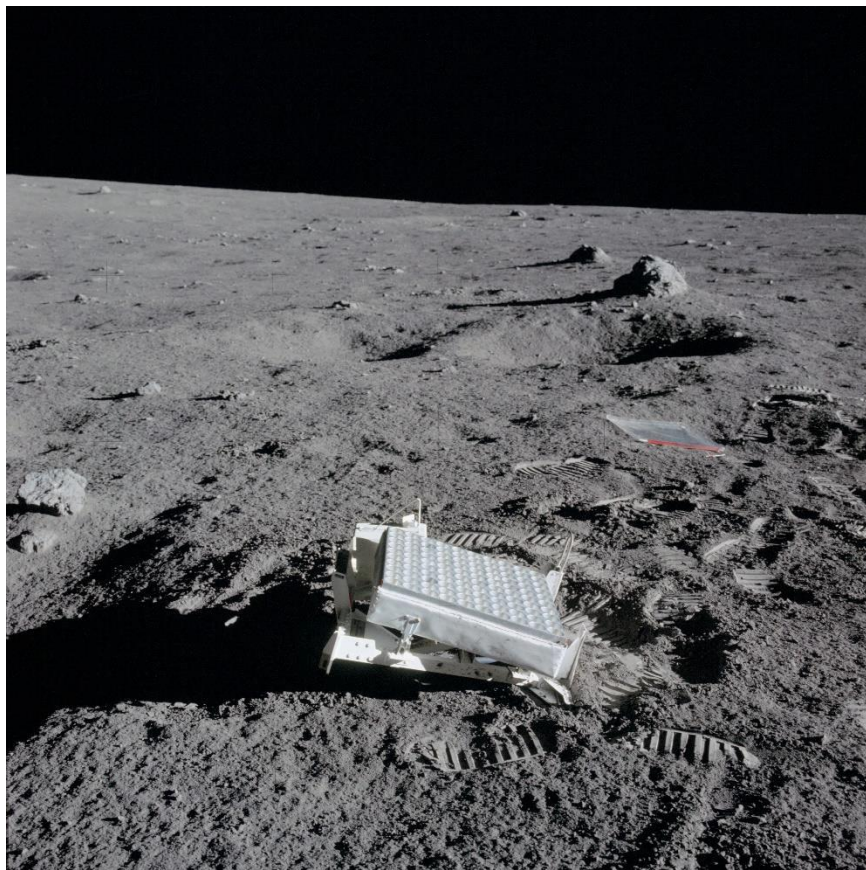

RANGE 238,900 mi

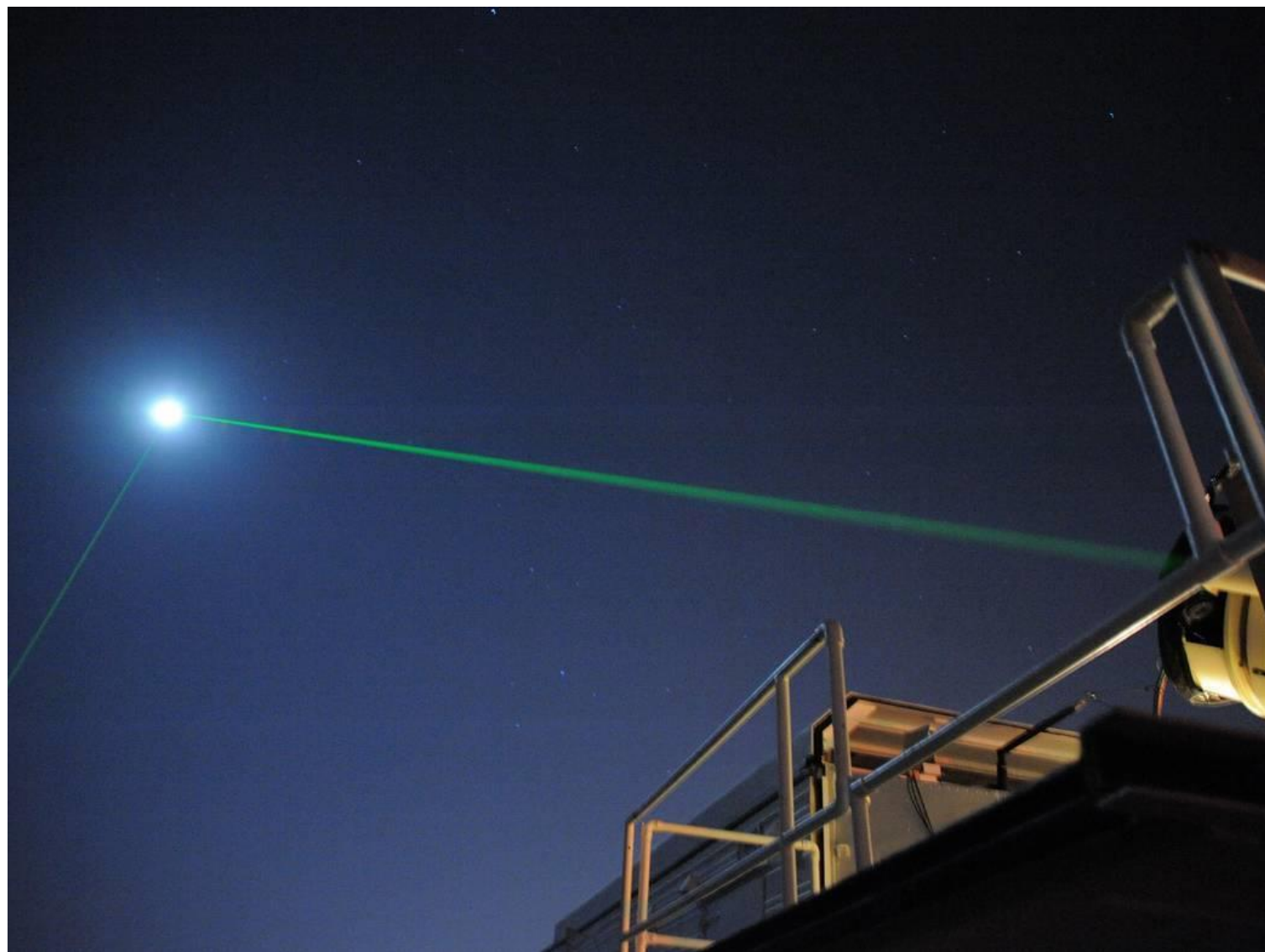

LiDAR vs. Cameras for Self Driving Cars – What's Best?

<https://www.autopilotreview.com/lidar-vs-cameras-self-driving-cars/>

Elon Musk

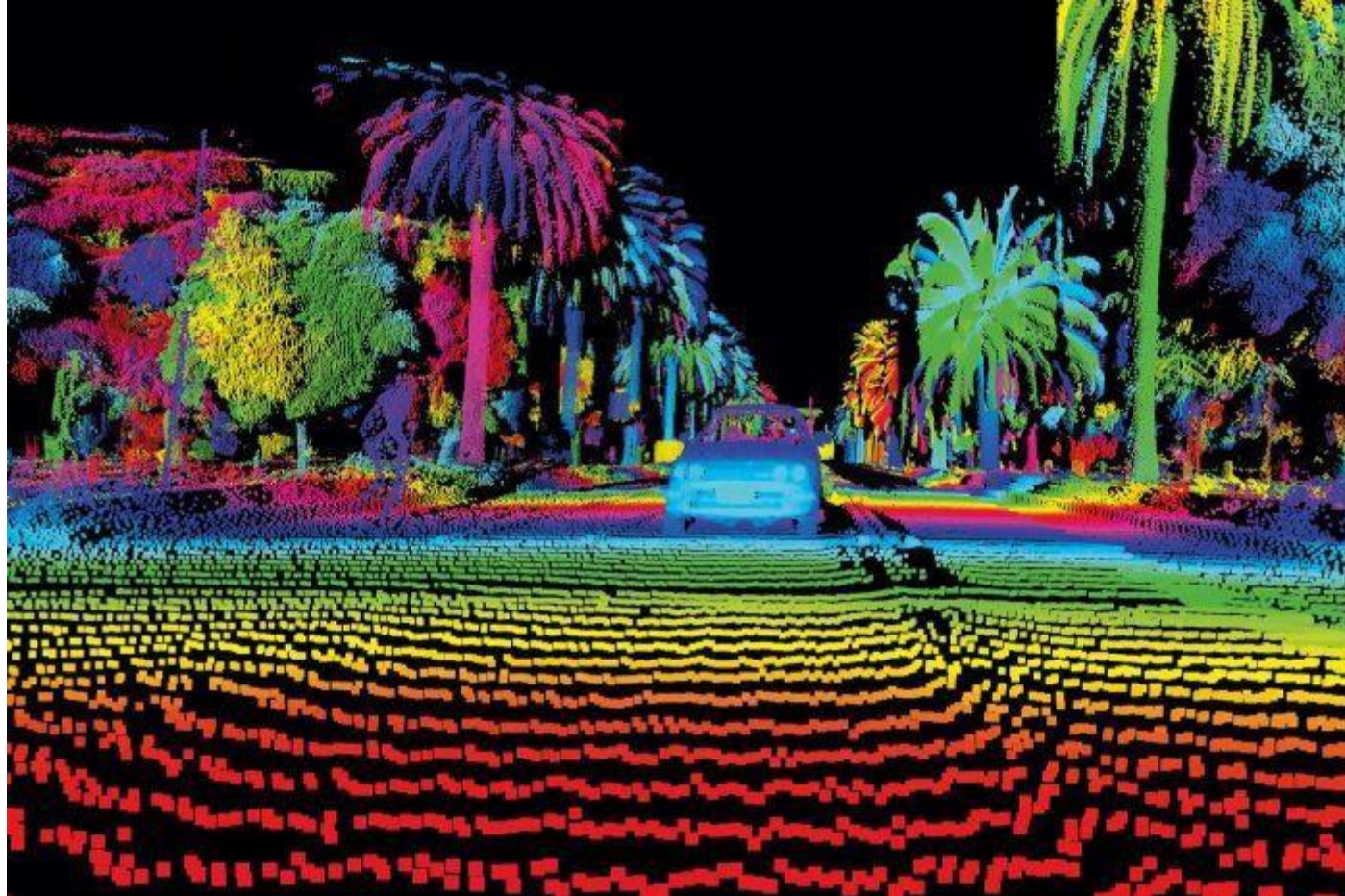



Elon Musk on Cameras vs LiDAR for Self Driving ...

ELON MUSK

“LIDAR IS DOOMED”



Watch later



Share

TESLA AUTONOMY DAY

Electro-magnetic Spectrum

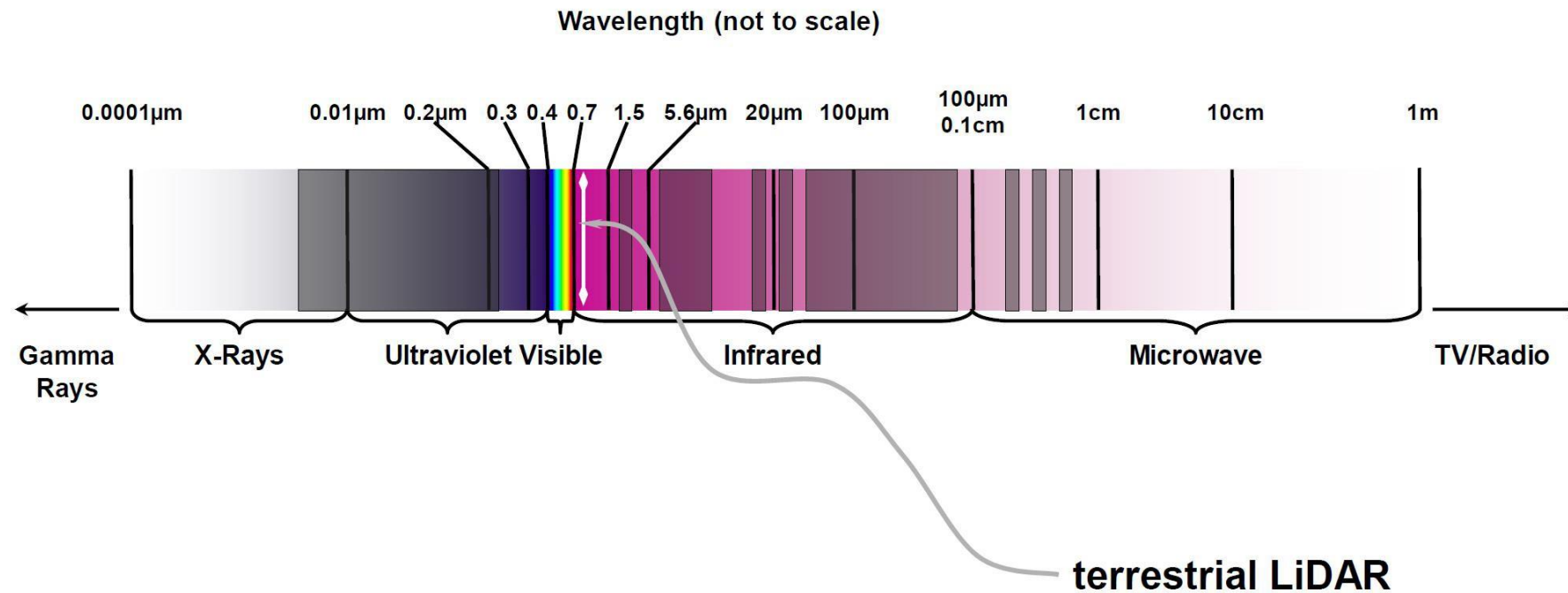

GPS

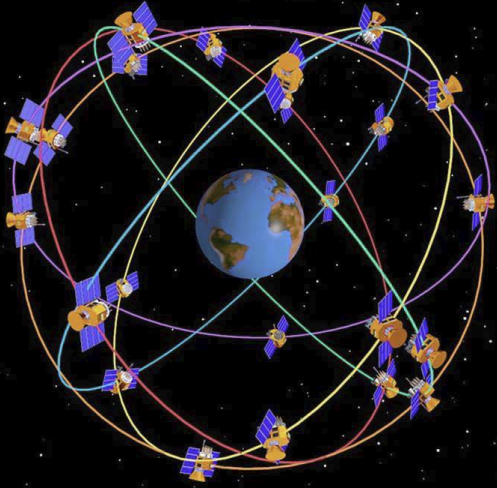

- GPS uses a constellation of between 24 and 32 Medium Earth Orbit satellites.
- Satellite broadcast their position + time.
- Use travel time of 4 satellites and trilateration.
- Suffers from “canyon” effect in cities.
- **Error up to 10 meters** in some cases. Not Indoors

RTK

RTK (Real Time Kinematic) corrections use one or more **local base stations** to augment the satellites in a GPS and increase a robot's certainty of where it is over GPS alone. Trimble, Leica, Topcon, and others all maintain networks of RTK base stations which can be utilized in covered areas with an Internet-connected RTK-capable GPS receiver for **an accuracy of 1-2cm.**

Use of existing base stations is either free or available for a fee- depending on the network. Commercial RTK bridges and repeaters can be deployed as base stations.

STUCK INDOORS?

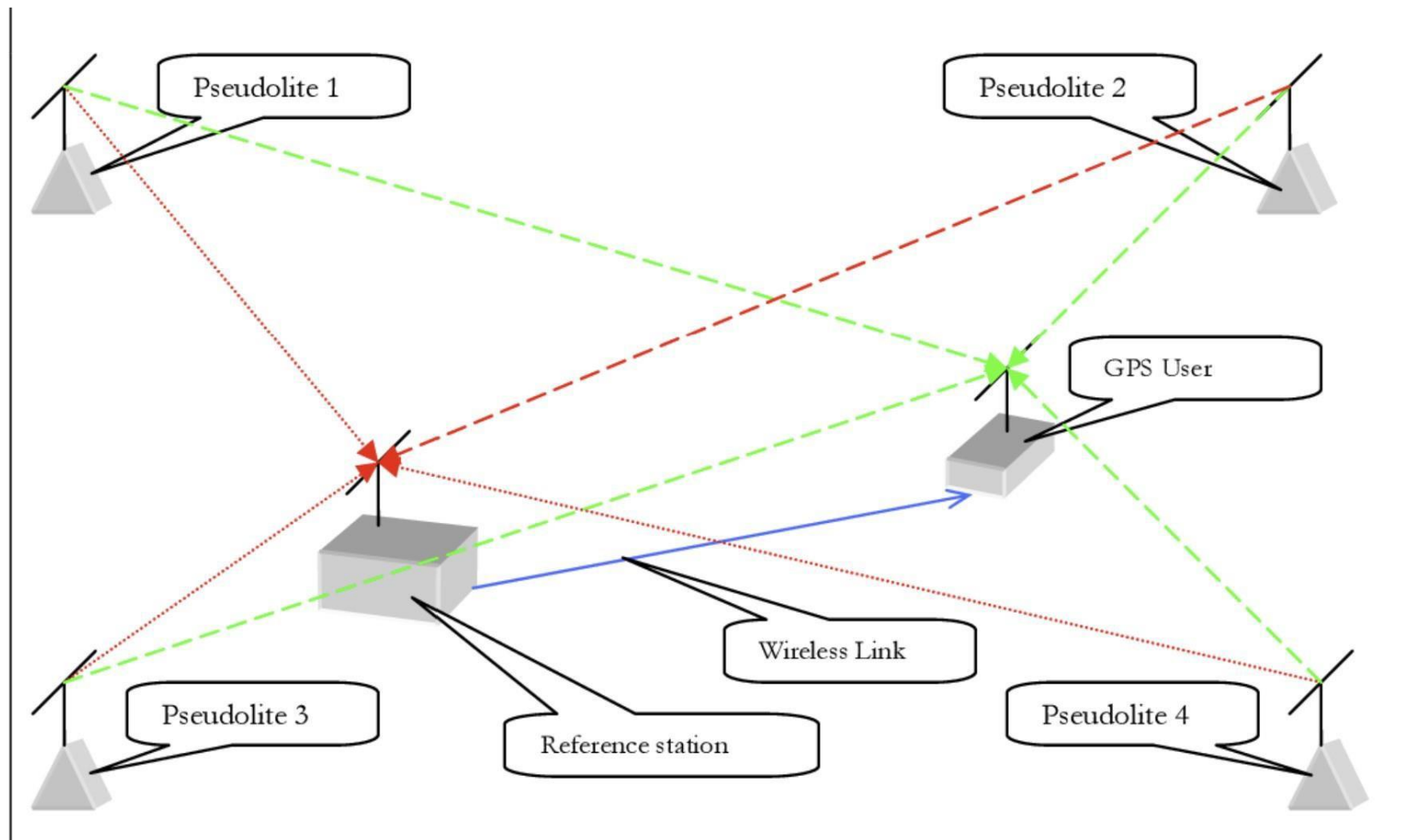

Figure 22: Asynchronous pseudolite system

Published in 2005

Indoor navigation with pseudolites (fake GPS sat.)

Rikard H. Eriksson, V. Badea



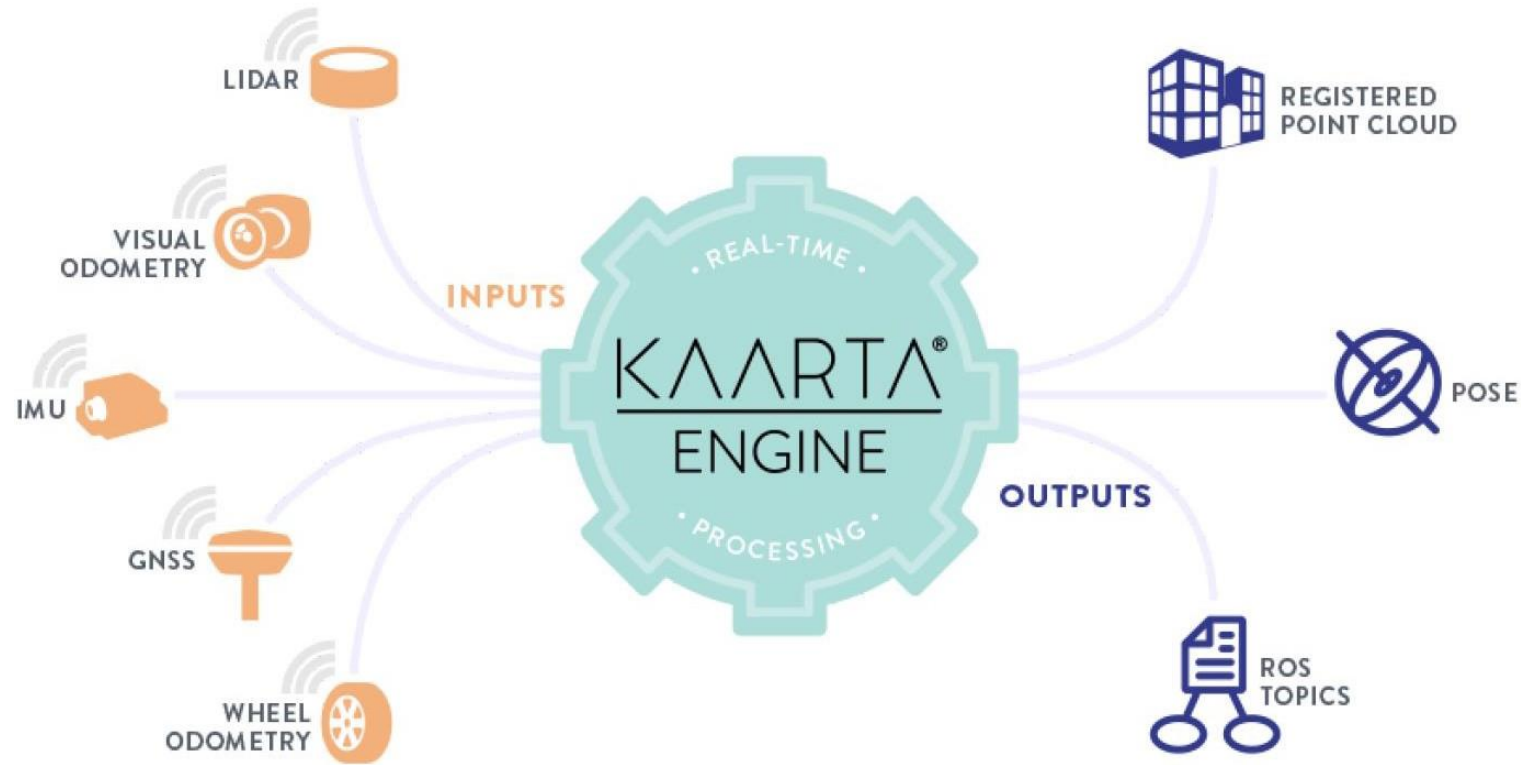

Some companies, such as Kaarta, offer pre-built sensor-fusion packages that ship with working SLAM. Kaarta's robot-mountable system, Traak, uses high quality sensors and runs one of the best algorithms in the world (Winner of Microsoft's indoor localization competition for multiple years and top of the KITTE benchmarks) on its internal computer. While most SLAM has drift rates in the 2%, Traak is typically 0.2% drift, an order of magnitude less. It both builds a map of the environment, can be used to determine a path, and follow that path. **It is priced at around \$27,000 for a single unit plus LiDAR** and also available as licensed software at a significantly lower price point.